

SICO[®] Harmony Choral Riser

Elevate your performance!

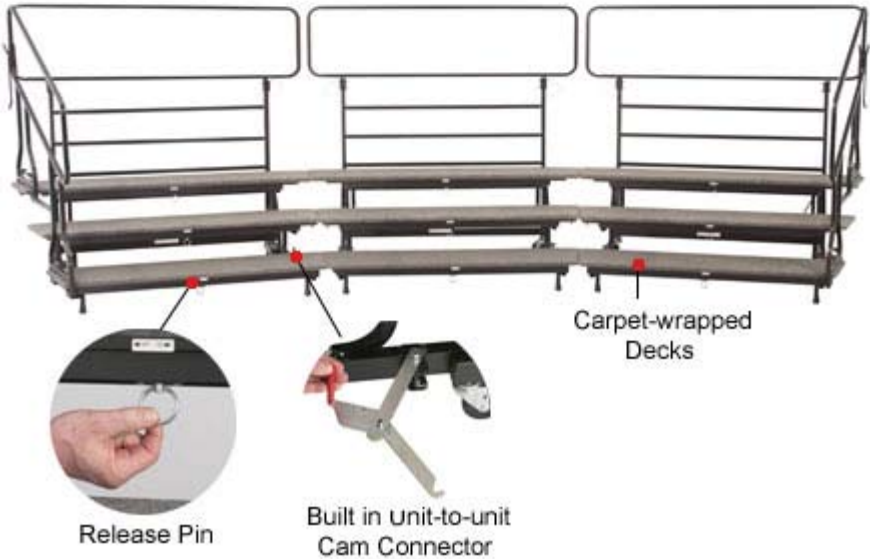
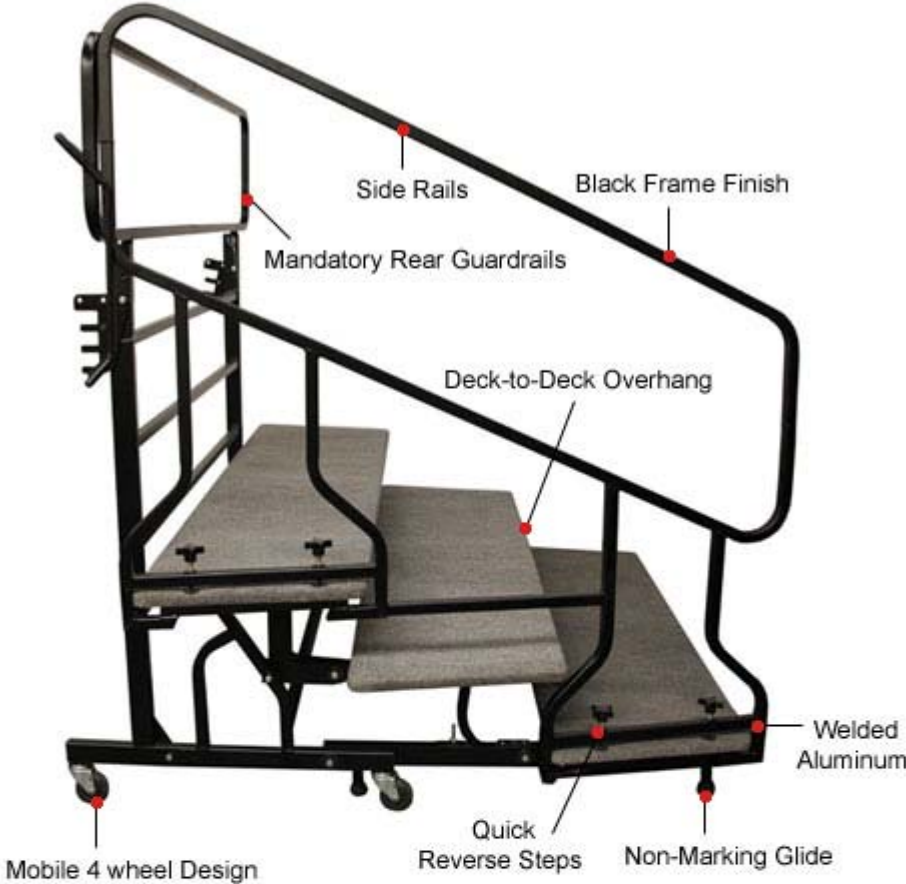

Features, Advantages & Benefits

Mandatory Rear Guardrails - Rear security guardrails come standard and are permanently attached to the back row of each riser for added safety. Bonus over other models: This guardrail also folds down over the unit to secure it in the transport mode.

Black Frame Finish - Attractive, non-reflective and professional appearance.

Mobile 4 wheel Design - Both 3 & 4 step models roll easily on 4 wheels and fit through a standard 36"(91cm) doorway. No loose parts to worry about.

Deck-to-Deck Overhang - One inch (2.5 cm) deck-to-deck overhang reduces chance of accidents caused by heels slipping between riser tiers.

Non-Marking Glide - Provides quiet, non-marring floor contact in the set-up position. Durable, neoprene glide comes complete with steel washer insert, to protect slide from wear over time.

Carpet-wrapped Decks - Carpet completely wraps tops and sides of all decks so they are always quiet, yet delivering an acoustical asset to your performances. Carpet also eliminates the possibility of catching robes on sharp edges.

Welded Aluminum - Deck frames are welded aluminum to minimize weight. One person can easily operate.

Easy Storage & Transport - Transport and storage are easy for staff. Easy to lift, easy to fold, and nothing to disassemble for storage makes it simple for staff to fold up units.

Folded Stability - Choral risers fold up for convenient transporting and storage. One simple lifting motion makes it easy to fold up units.

Built in Unit-to-unit Cam Connector secures units together and locks them into place. No gaps between units for heels to slip through. Nothing to unbolt or unscrew for set-up or take-down when you change configurations.

Quick Reverse Steps Change arrangement of units in minutes without tools.

Optional Side Rails - Locks onto pivoting top rail without tools. Side rails mount to back of unit when in stored position. One side rail kit is all you need to protect both ends. This added safety feature is highly recommended.

Serial Number - Branded into framing for easy identification.

Free Space Analysis - SICO® provides free CAD drawings showing accurate dimensional layouts of choral risers placed within your facility.

Shipped Fully Assembled - Everything is contained in one unit, no parts to carry or add on.

Warranty – Protected by a **15-Year Warranty** against manufacturer's defects. **Lifetime Warranty** on welds.

Specifications

Model No.	Description	Top Riser Height	Weight	Cu.Ft
2611-324B	3-Step	24" (60.9cm)	172 lbs.	50.7
2611-432B	4-Step	32" (81.3cm)	221 lbs.	80.9
C2612-34GRDB	Set of 2 side rails with 2 storage hangers		81 lbs.	23

Powder Coated Frame Options



Black (B)

Carpet Options



Cloud Grey

4-Riser Choral Riser Capacity Chart

Units	Group Capacity *	Width and Depth
2	32-40	12' 10" x 6' 11 1/2" (391cm x 212cm)
3	48-61	18' 10 1/2" x 7' 7-3/4" (575cm x 233cm)
4	64-82	24' 5" x 9' 1/2" (744cm x 276cm)
5	80-103	29' 4 1/2" x 10' 4 1/4" (895cm x 316cm)
6	96-124	33' 7 3/4" x 12' 3 1/4" (1026cm x 374cm)
7	112-145	37' 3/4" x 14' 3/4" (1130cm x 429cm)
8	128-166	39' 7 3/4" x 16' 4" (1208cm x 498cm)
9	144-187	41' 1 1/2" x 18' 5" (1253cm x 561cm)
10	160-208	41' 8" x 20' 10 1/2" (1270cm x 636cm)

3-Riser Choral Riser Capacity Chart

Units	Group Capacity *	Width and Depth
2	24-32	11' 11" x 5' 3 3/4" (363cm x 162cm)
3	36-48	17' 6 1/2" x 5' 11 3/4" (535cm x 182cm)
4	48-64	22' 9" x 7' 5 1/4" (693cm x 227cm)
5	60-80	27' 5 1/2" x 8' 10" (837cm x 269cm)
6	72-96	31' 5 1/2" x 10' 8 3/4" (959cm x 327cm)
7	84-112	34' 8" x 12' 6 3/4" (1057cm x 383cm)
8	96-128	37' 1/2" x 14' 10 1/2" (1129cm x 453cm)
9	108-144	38' 6" x 16' 11 3/4" (1173cm x 518cm)
10	120-160	39' 1/2" x 19' 6" 1/4" (1190cm x 595cm)

* **First Group Capacity Number:** Performers shoulder to shoulder.

* **Second Group Capacity Number:** Performers facing center, shoulders turned in.
Capacities based upon average size high school performers with one row on floor.

SICO[®] Harmony Choral Riser Dimensions

Three Step Choral Riser Dimensions

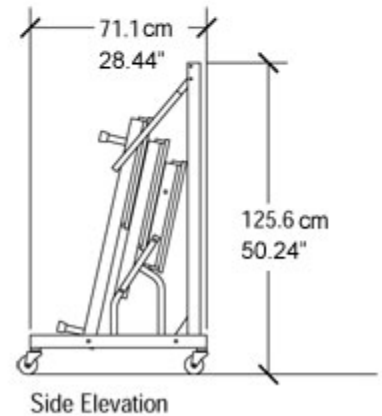
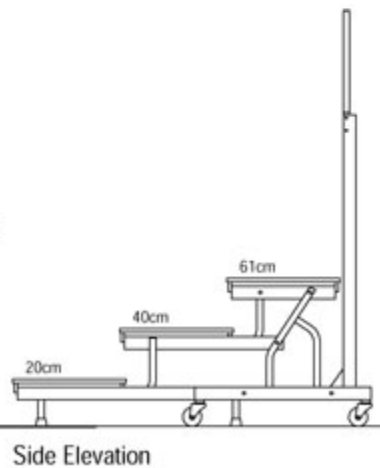
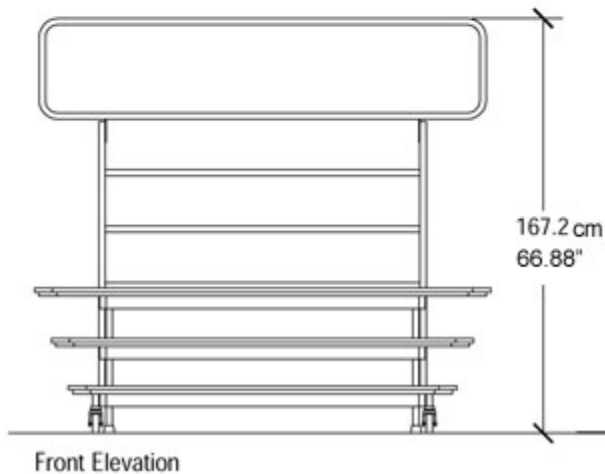
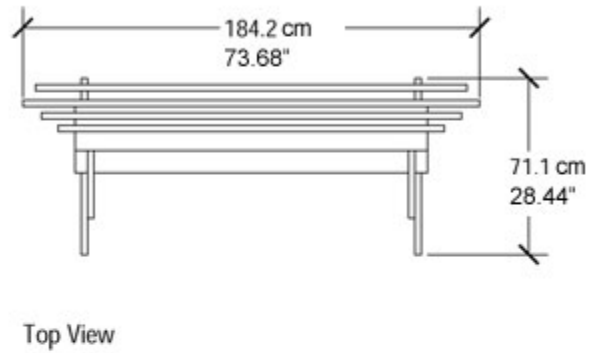
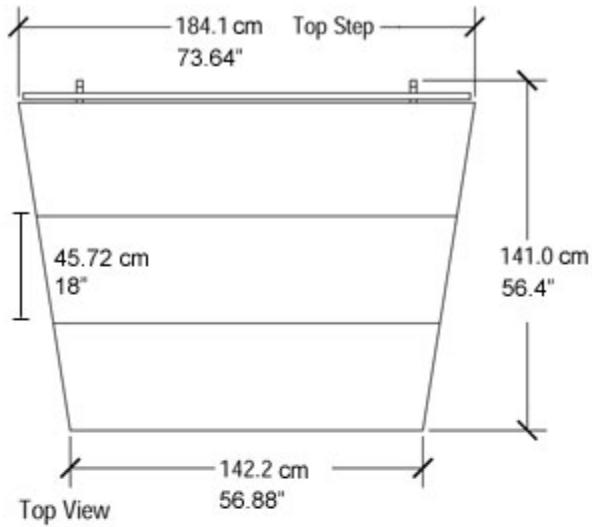

Open Choral Riser Dimensions

Storage Configuration

Four Step Choral Riser Dimensions

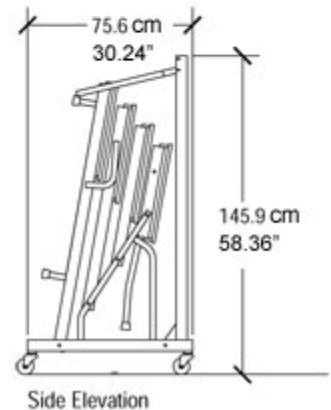
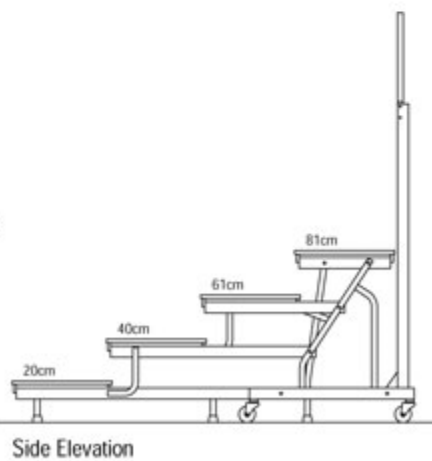
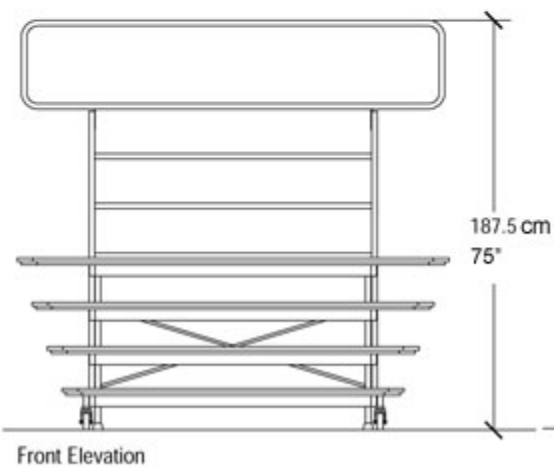
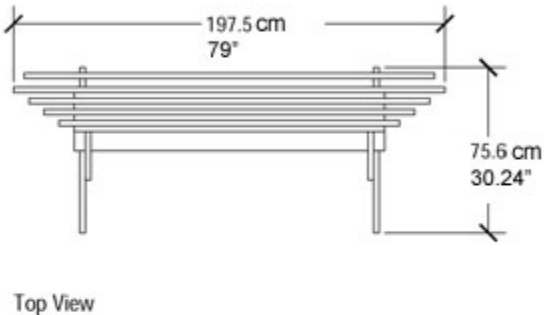
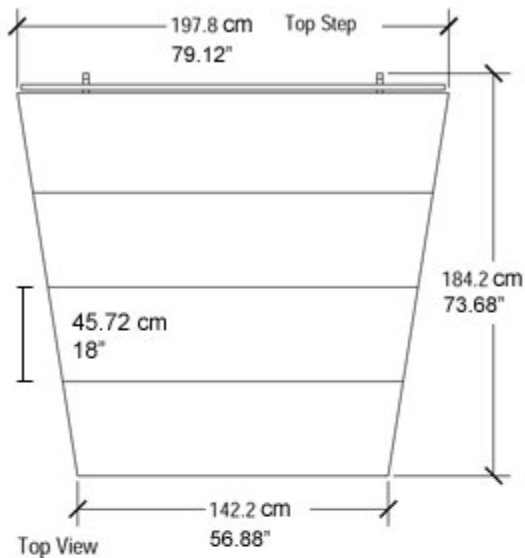

Open Choral Riser Dimensions

Storage Configuration



For More Information Visit: <http://www.sicoinc.com/choralrisers.php>
 7525 Cahill Road, Minneapolis MN 55439
 1.800.533.7426