



# Owner's Manual

## Venue Maker Pro™ Stage\*

---

### Before you begin...

**WARNING!** Read and understand these instructions to become a trained person before operating. Failure to do so may result in serious injury.

Use care when lifting, pushing or pulling these units. Never lift more than you are able to safely handle.

At least two people are required to safely operate a Venue Maker Pro™ Stage.

### No Extra Tools Required

Hex Wrench - 5/16" (8mm) - supplied  
Open End Wrench - 1-1/8" - supplied

Keep this manual in a safe place for future use.

If you have any problems during setup, contact SICO® Customer Care at 1.800.424.0796.

---

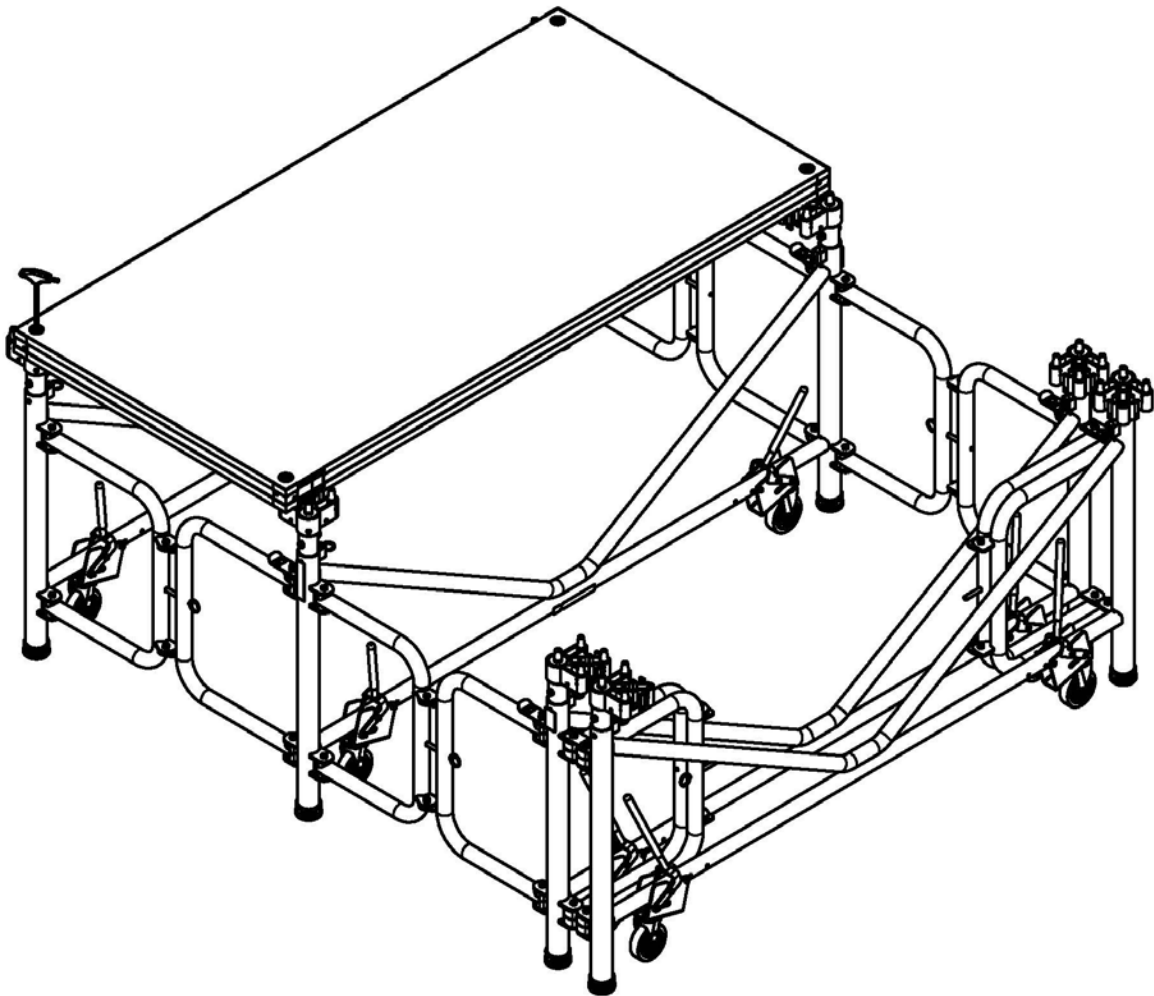

# Introduction

The Venue Maker Pro™ Stage is a mobile folding performance stage system used to build platforms of various sizes to facilitate stage performance events.

Typical multi-use venues for the Venue Maker Pro Stage are arenas, convention centers, and auditoriums.

Ensure that the floor/ground is stable enough to place your Venue Maker Pro™ Stage product.

THE VENUE MAKER PRO™ STAGE IS INTENDED FOR INDOOR USE ONLY.

Available sizes of frame units:

- 8' X 12' [2.44m X 3.66m]
- 8' X 8' [2.44M X 2.44M]
- 4' X 8' [1.22m X 2.44m]

Available height ranges and height increments are:

- 32" - 48" [82cm - 122cm], 2" [5cm]
- 40" - 60" [102cm - 152cm], 2" [5cm]
- 48" - 78" [122cm - 198cm], 2" [5cm]

Structural Decks

- 4' X 8' [1.22m X 2.44m]
- Reversible
- Can bridge between ends or sides of frame units.
- Structural Deck 125 lbs., [61kg]

Load ratings

- 104.4 psf [5.0 kN/m<sup>2</sup>] uniformly distributed load.
- Maximum point load on top of the stage: 337lb on 2" x 2" [1.5kN on 5cm x 5cm]

Pin connectors connect the structural decks to the frame units. Each adjustable column utilizes a pin connector.

Accessories include

- Guardrails
- Step assemblies
- Drapes
- Ramp

Terminology - a "frame unit" consists of a set of pin connectors and the related folding understructure.

Please retain these instructions.

- Regular inspection of the Venue Maker Pro™ Stage is recommended; check all fasteners for tightness and damage; also check for damage to stage components.
- Replace any damaged component before the Venue Maker Stage is put back into service.

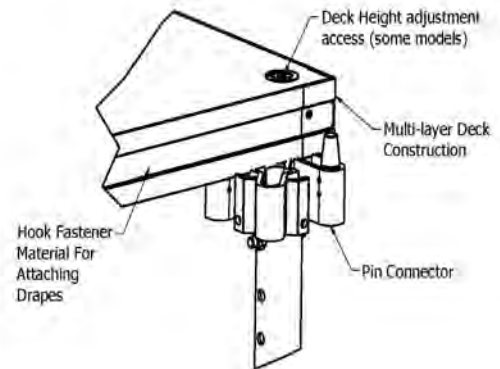
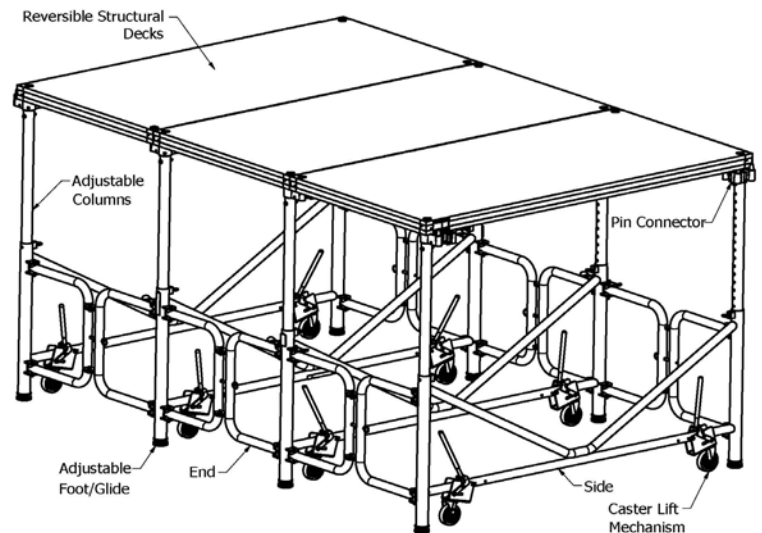

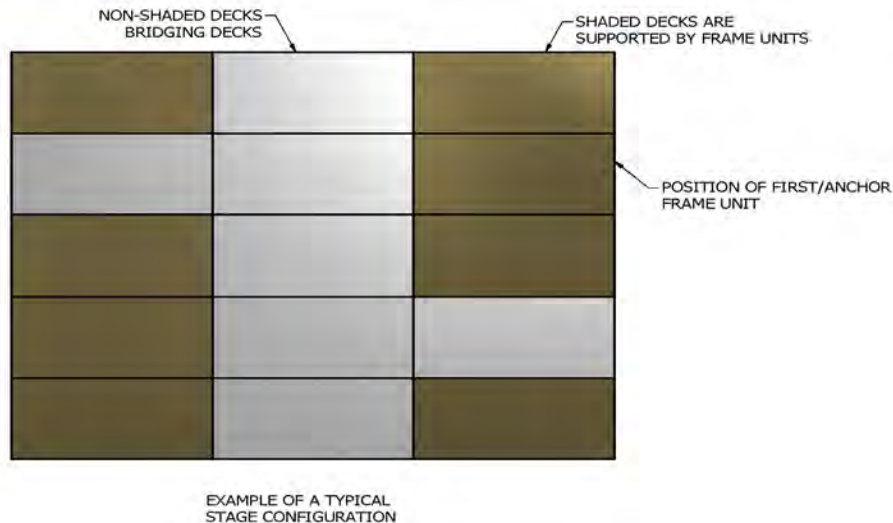

## Stage Placement & Setup

**SICO RECOMMENDS:** When constructing a stage system, the first frame unit to be positioned in the farthest rear left or right corner and the stage is built out from that point. (See example above)

Roll first frame unit into near final build position (while still on the caster wheels). Open frame; a pin will automatically engage to lock side elements in position.

**Adjusting Column Height:** Grasp column firmly, pull pin outward (to dis-engage) turn column slightly so holes and pin don't line up. Set column to desired height and re-engage pin; always check pin for full engagement.

When setting deck height take note of the legend attached to one of the frame members.

Apply stage decks. **Note:** Pin connector orientation and pin position vary with position of frame unit in setup.

### Additional Frames and Decks:

- Adjust the pin connector orientation and pivot pins as required for desired stage layout.
- Repeat for additional frame units and install bridge decks as required.

**Caution:** SICO recommends that the deck/stage not to be loaded until its completely assembled and resting on the foot/glide system.

Once the entire stage system is assembled it can be lowered on to the foot/glide. To not cause undo stress on the stage/deck system, the recommended lowering procedure is as follows:

- Start at a corner of the stage system. Lift the handle on the caster assembly to lower the glide to the floor.
- Lower each caster assembly across the entire back/front & then move in to the next row of caster assemblies and lower that entire row. Follow this procedure for remaining rows of caster assemblies.

**Adjust Stage Height:** See Page 5 for details.

The stage is now ready to attach:

- Guard rails
- Step assemblies/Ramps
- Drapes

# Pin Connectors

Pin connectors are located on each column of the frame unit. There are two types of pin connectors available:

- Standard pin connector
- Optional pin connector w/deck leveling system.

All pin connectors have three pivot pins that rotate from the upright "USE" position to a retracted "STORAGE" position.

To adjust the pins within the pin connector:

- From "STORAGE" position to "USE" position simply rotate pin "UP" until vertical. (Pin is self locking)
- From "USE" position to "STORAGE" position simply lift pin and rotate down.

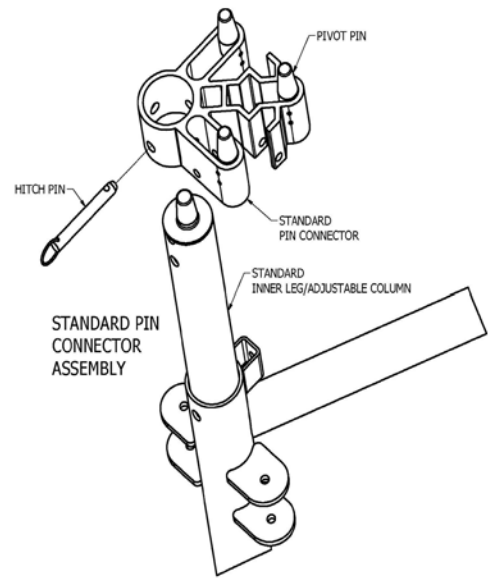

## Standard Pin Connector

Standard pin connector is attached to the standard adjustable column/inner leg with a hitch pin through upper most hole on leg assembly.

### Standard Pin Connector Orientation

To change orientation, remove hitch pin, rotate pin connector to desired position re-install hitch pin.

**Caution:** Check hitch pin to insure that its fully engaged.

(i.e., hitch pin ball detent extends beyond both walls of pin connector housing).



## Optional Pin Connector w/Deck Leveling System

Optional pin connector is attached to a deck leveling apparatus, which in turn is attached to the top deck leveling system's adjustable column/inner leg.

### Optional Pin Connector Orientation

By pulling on the "YELLOW" pin release lever (see upper drawing) the pin connector will rotate. Once pin connector is near the desired position, release lever and it will automatically lock into position.

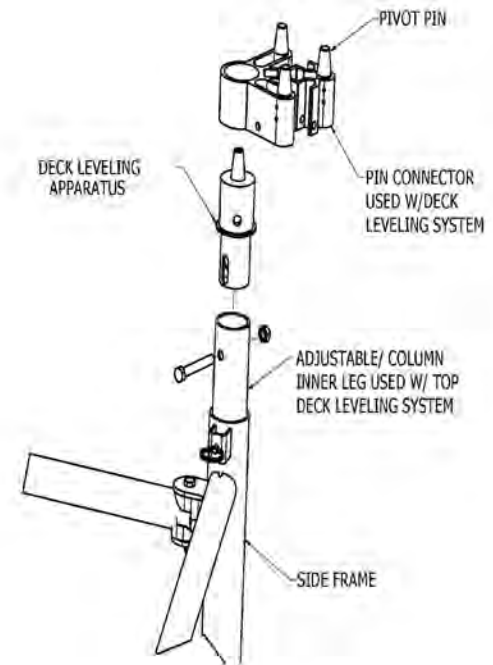

---

## Leveling the Venue Maker Pro™ Stage

Leveling the Venue Maker Pro™ Stage system provides an even, safe surface.

### Sico Recommended Good Practice:

Once all caster lift assemblies have been raised, check that all feet/glides are touching the floor surface. With the provided 1-1/8" open end wrench, adjust feet/glides as necessary.

To avoid risk of tripping, the height difference between decks should be under 2mm when unloaded, and less than 4mm at maximum load.

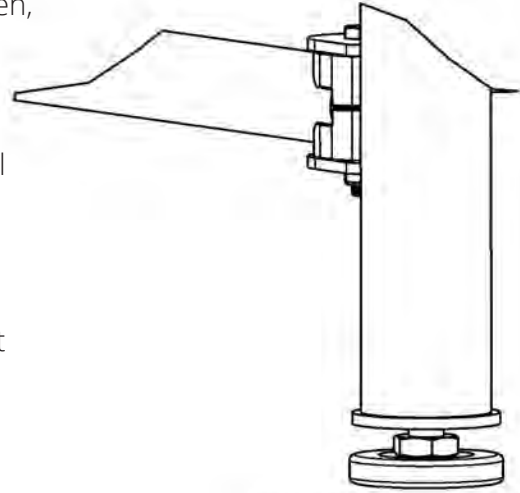

STANDARD ADJUSTMENT W/PROVIDED  
1-1/8" OPEN END WRENCH  
(GLIDE EXTENDS DOWN UP TO 5")

## Leveling the Venue Maker Pro™ Stage w/Optional Top Deck Leveling (Fine Adjustment )

Adjust glides as described above before proceeding with top deck leveling.

The top deck leveling fine adjustment is located above the column of each frame unit (i.e., non-bridging) deck. Rotate hex wrench clockwise to lower decks or counterclockwise to raise decks.

To avoid risk of tripping, the height difference between decks should be under 2mm when unloaded, and less than 4mm at maximum load.

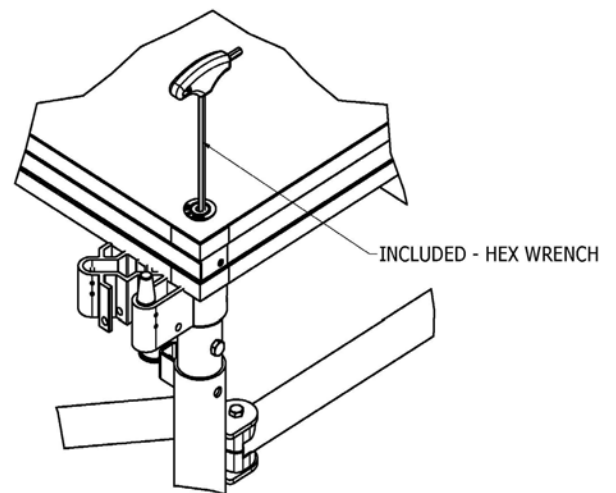

OPTIONAL TOP DECK LEVELING  
(FINE ADJUSTMENT)

---

# Handling Your Venue Maker Pro™ Stage

## When handling your stage, remember to:

- Use two people to safely move and handle the stage sections and accessories.
- To prevent injury and damage to product, do not drop the stage sections or accessories.

## Cleaning - The Deck surface

### When cleaning your stage, remember to:

- Carpet - Vacuum clean with brush attachment, (Spray carpet cleaner can be used for stains).
- Tuffdeck or fiberglass - Household cleaning detergent with water and soft bristle brush. Dry with sponge, sponge mop, or micro-fiber cloth.

## Maintenance

- Lubricate pivot points before every use.
- Remove heavy dirt or debris from frame members .
- Wipe with damp cloth.
- Touch-up scratches w/paint.

## Disassembly

- Remove drapes, guardrails, ramps, stairs and decks.
- Adjust inner leg columns to there lowest position.
- Engage caster assemblies in wave pattern, starting in one corner of assembled stage.
- Disengage lock pins on frame unit ends and fold the frame unit until storage lock engages. Note: 4' x 8' frame does not lock in folded position. Move to storage.

## Decommissioning

The black/yellow painted parts and bolts/nuts are steel. The pin connectors are aluminum. Please recycle. The decks should be disposed of in a waste to energy facility.

## Guardrail Systems

There are currently Two (2) Guardrail systems for the Venue Maker Pro™ Stage System.

- Refer to the information sheets, for pin connector mounted guard rails (SGP Series) or for the clamp style guard rails (SGU Series).

## Specifications

SICO's stage decks would have an overall flame spread rating similar to that of plywood, which generally falls in the Class III (or Class C) rating.

**⚠ WARNING**

**Attach GUARDRAILS and CHAIRSTOPS to platform to avoid falls.**

**Lock STEPS to platform to avoid movement.**

**Failure to do so could result in serious injury.**

Printed in U.S.A 02/14 Rev A 107569

# Attaching Accessories

**Step Assemblies** – SICO's articulating step units can cover the entire height range of a Venue Maker Pro™ Stage system, so the same step assemblies can be used for any height within the range of your particular Venue Maker Pro™ Stage. These step assemblies come with an Owner's Manual. Fixed height step units are also available. Read and follow the instructions contained therein to ensure a secure setup.

- **Ramp System** – SICO's ramp provides accessibility to the Venue Maker Pro™ Stage. The slope is 1" of rise per 12" [1cm of rise per 12cm] of horizontal travel, with the appropriate handrails, landings and turn-arounds as required for your particular setup. Ramp sections are available in 6" [15cm] and 8" [20cm] rise per section. The ramp system comes with an Owner's Manual. Read and follow the instructions contained therein to ensure a secure setup.

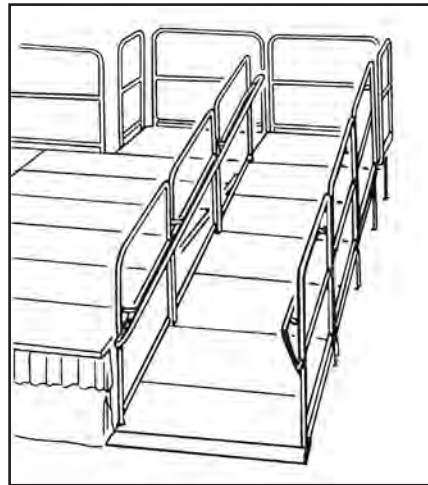
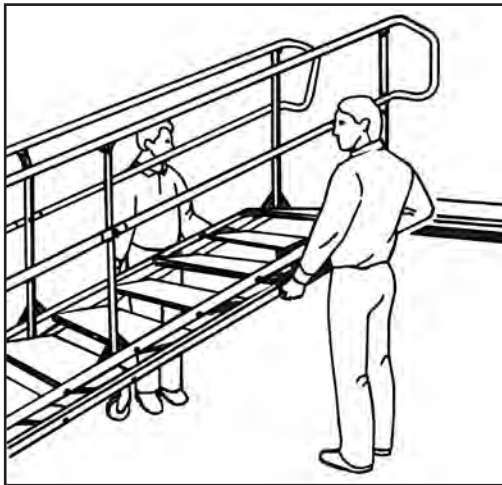

- **Closure Drapery** – Stage drapes are available in single heights and adjustable heights. An adjustable height drape can be adjusted to match the stage height selected for a specific event. There is a strip of hook fastener along the bottom edge of the drape and multiple strips of loop fastener parallel to the bottom edge of the drape. For the tallest stage height, these hook and loop fasteners are not used. For shorter stage heights (i.e., shorter drape heights), simply align the hook fastener from the bottom edge of the drape with the appropriate strip of loop fastener to achieve the desired drape length.
- Attach the drape to the deck by attaching the loop fastener at the top of the drape to the hook fastener on the deck perimeter.
- One end of the drape has a short strip of hook fastener near the top and on the front; this allows you to overlap adjacent drapes.

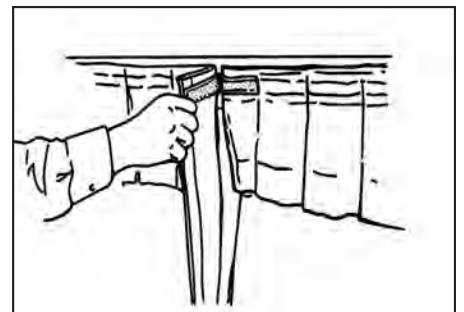
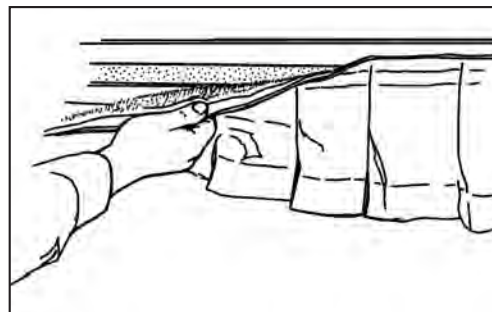
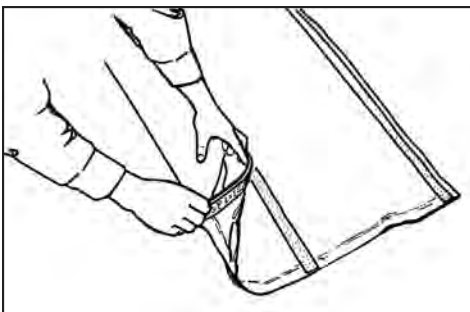

If parts are needed, use only original SICO parts.

ITEM	DESCRIPTION
6	SPACER
19	NUT STOP M10x1.5MM
20	SCR C HH M10x1.5x110MM
22	TUBE GRAVITY LOCK
23	SPRING .500 Long,.600 OD,.045 WIRE
24	MACH BUSHING 7/8 X 17/32
25	TUBE END CAP
34	WELDMNT, CENTER SUPPORT

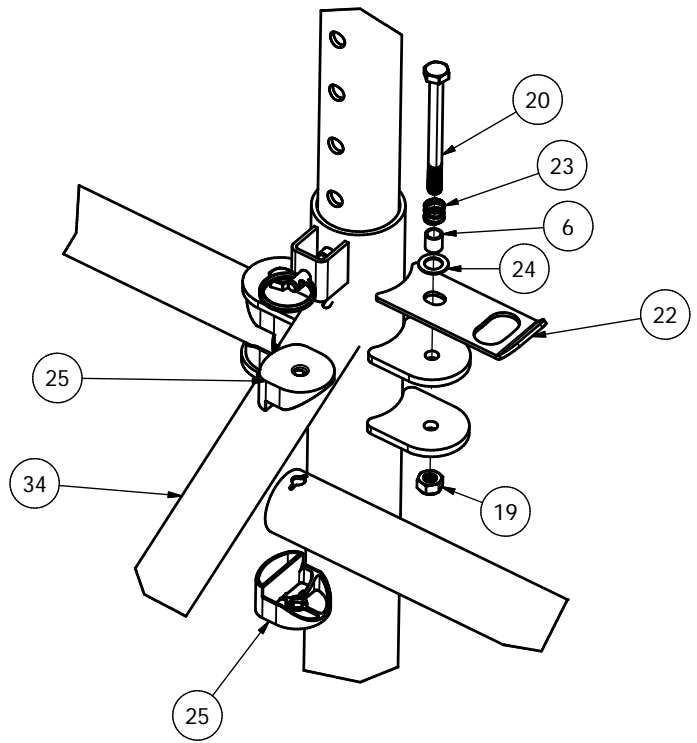

ITEM	DESCRIPTION
19	NUT STOP M10x1.5MM
21	SCR C HH M10x1.5x90MM
25	TUBE END CAP
32	WELDMNT, C-TUBE, 18.68
35	WELDMNT, C-TUBE, 20.68

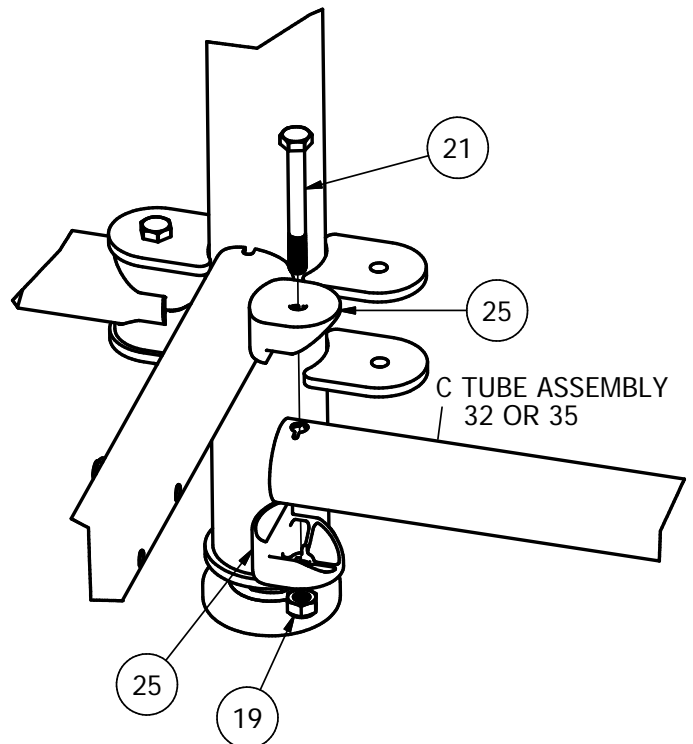



ITEM	DESCRIPTION
17	SCR C HH M10x1.5x30MM
18	3/8" ID, 2" OD OVERSIZED WASHER
19	NUT STOP M10x1.5MM
32	WELDMENT, C-TUBE, 18.68
35	WELDMENT, C-TUBE, 20.68

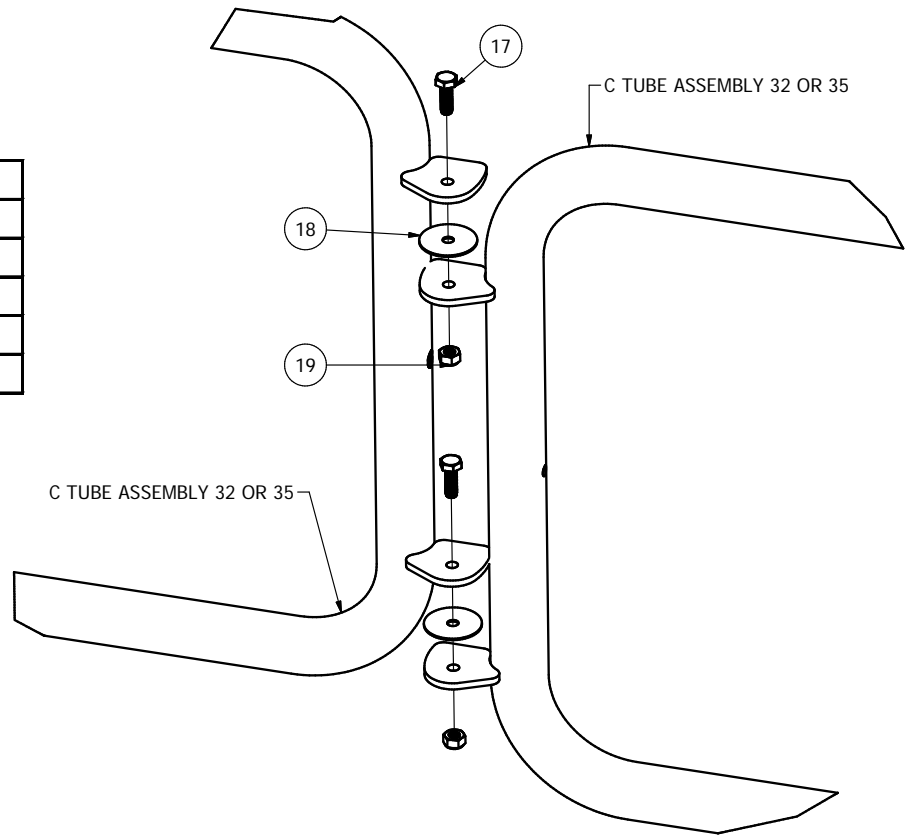

ITEM	DESCRIPTION
12	SPRING COMPRESSION
14	RING, SPLIT
16	LOCK PIN LONG
32	WELDMENT, C-TUBE, 18.68
35	WELDMENT, C-TUBE, 20.68

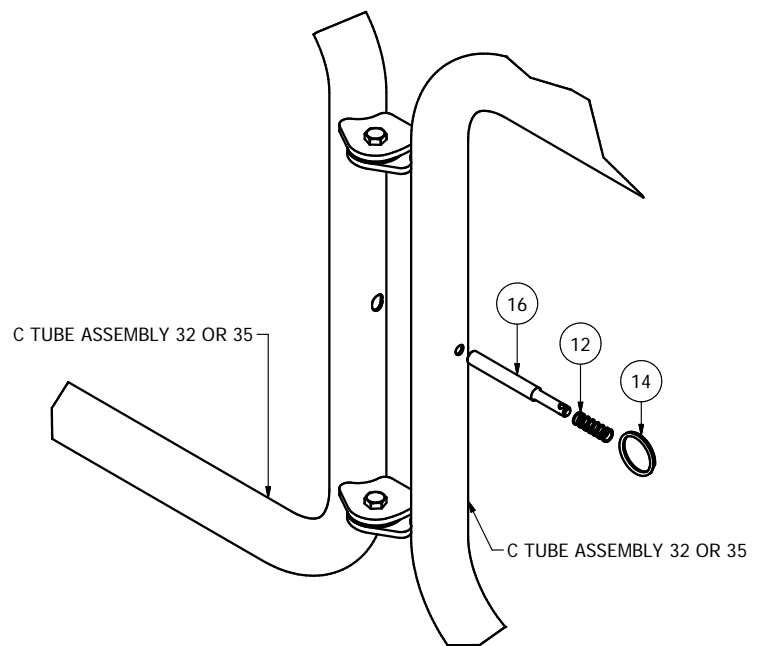

ITEM	DESCRIPTION
12	SPRING COMPRESSION
13	WASHER, 3/8" SAE
14	RING, SPLIT
15	LOCK PIN
33	WELDMENT, OUTSIDE SUPPORT

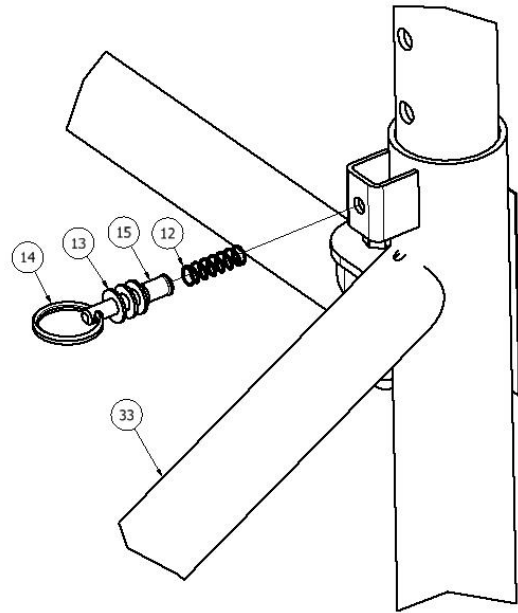

ITEM	DESCRIPTION
27	PIN CONNECTOR ASM
28	INSIDE COLUMN

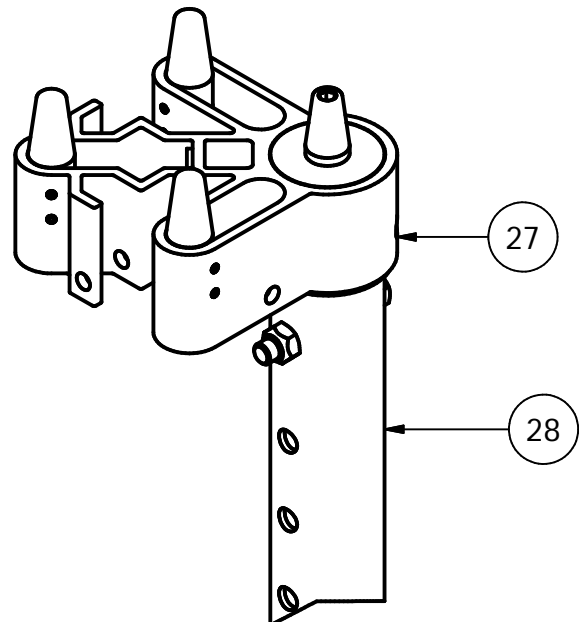

Notes:

1. Standard pin connector and optional pin connector w/deck leveling system are not interchangeable.
2. Inside column for standard pin connector is not interchangeable with inside column for optional pin connector w/deck leveling system.

ITEM	DESCRIPTION
1	CASTER, 5IN SWIVEL
2	CASTER RELEASE U BKT W/ SLOT
3	NUT-STOP, .50-13
4	3/8-24 N.F. X 3.00 HEX HEAD
5	SCR C HH .38-24X3.5 GRADE 5 ZINC
6	SPACER
7	CASTER RELEASE HANDLE, RH
8	CASTER RELEASE HANDLE, LH
9	SPACER
10	GRIP
11	NUT JAM .38-24
26	GLIDE, PVC COATED

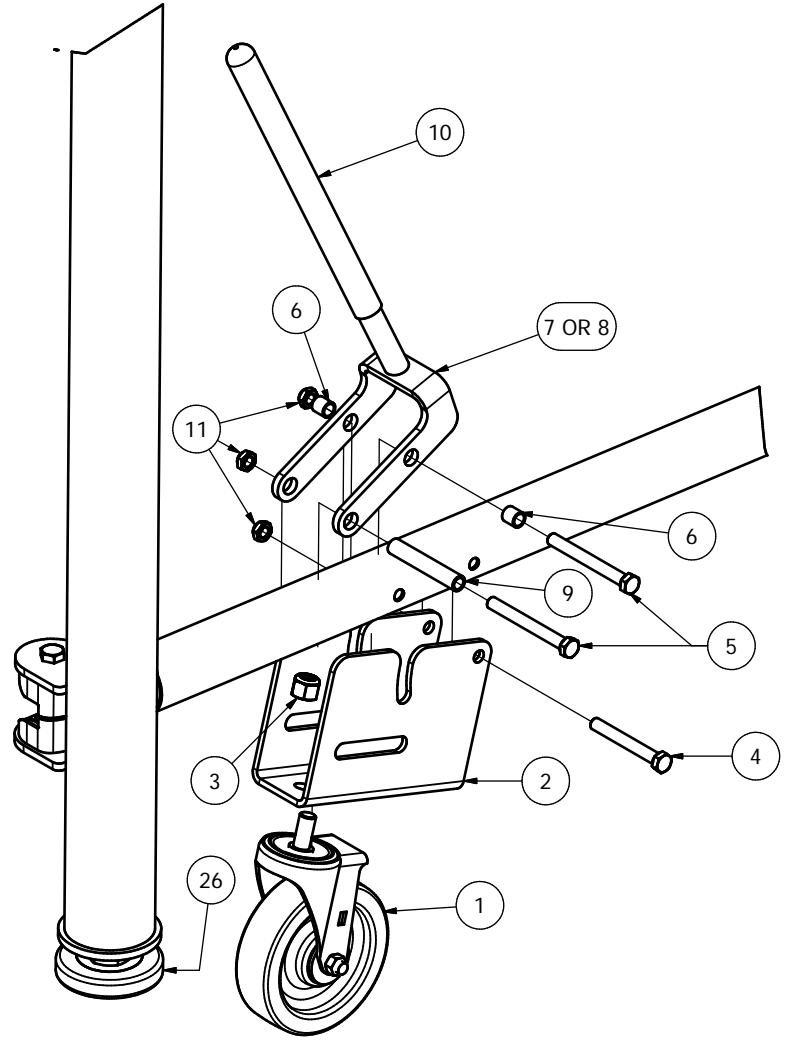

# Unit to Unit Connector, Venue Maker Pro™ Stage

When handling your stage, remember to:

- Unit to Unit connectors are required when frame units are adjacent to each other (i.e., without a bridging deck between them) to prevent gaps from developing between decks.
- Use two people to safely move and handle the stage sections and accessories.
- To prevent injury and damage to product, Do Not Drop the stage sections or accessories.

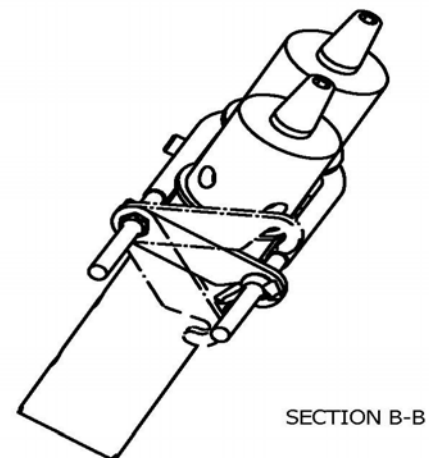
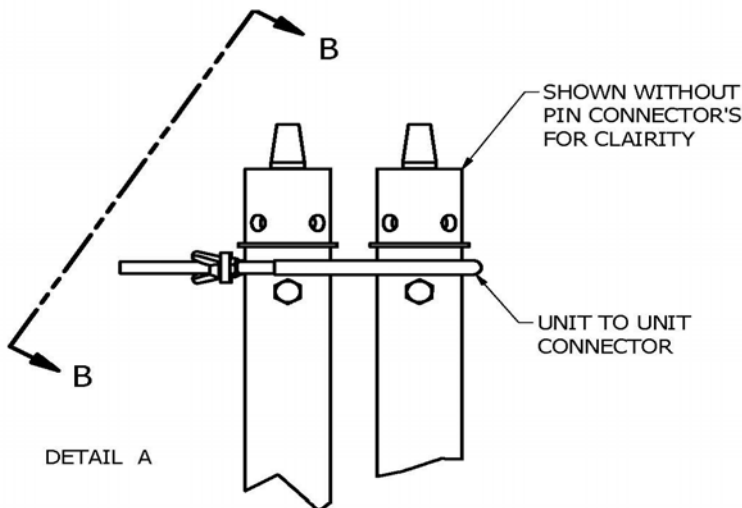
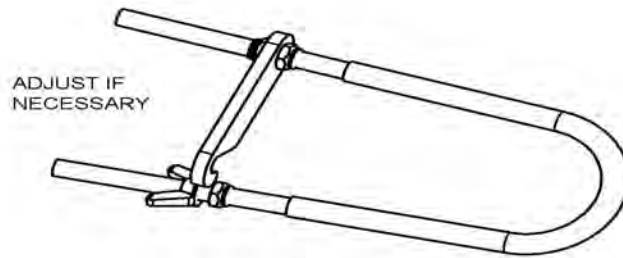

TWO DOUBLE FRAME UNITS CONNECTED WITH UNIT TO UNIT CONNECTORS

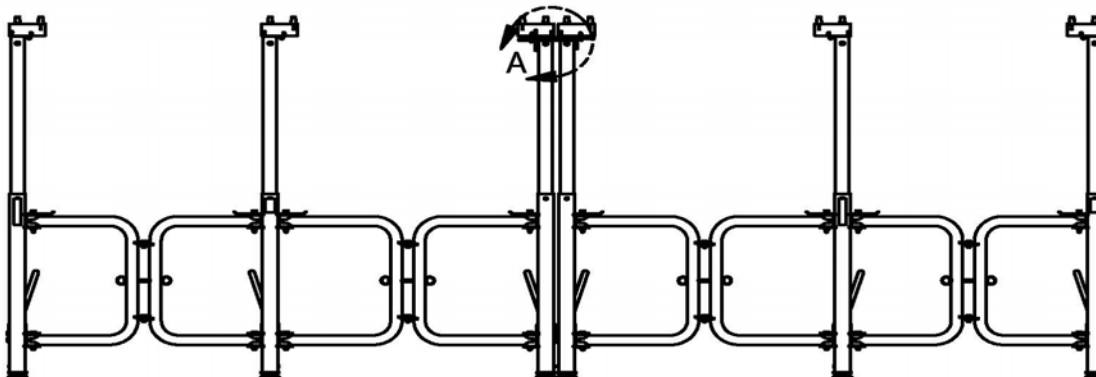

---

# Sway Brace Installation, Venue Maker Pro™ Stage

## When handling your stage, remember to:

1. Use two people to safely move and handle the stage sections and accessories.
2. To prevent injury and damage to product, Do Not Drop the stage sections or accessories.
3. Sway braces may be desirable when columns are adjusted to, or near the, maximum height.

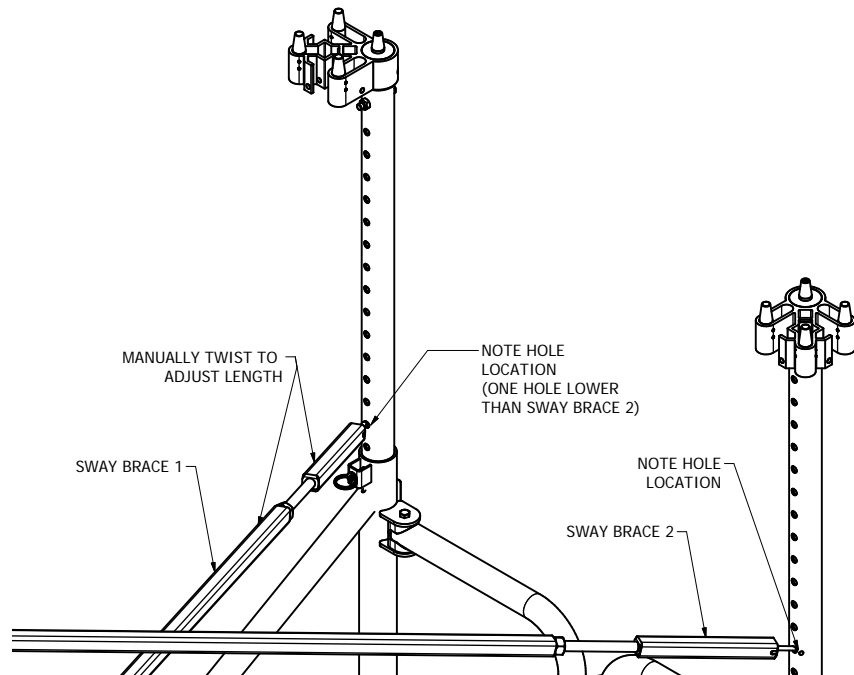
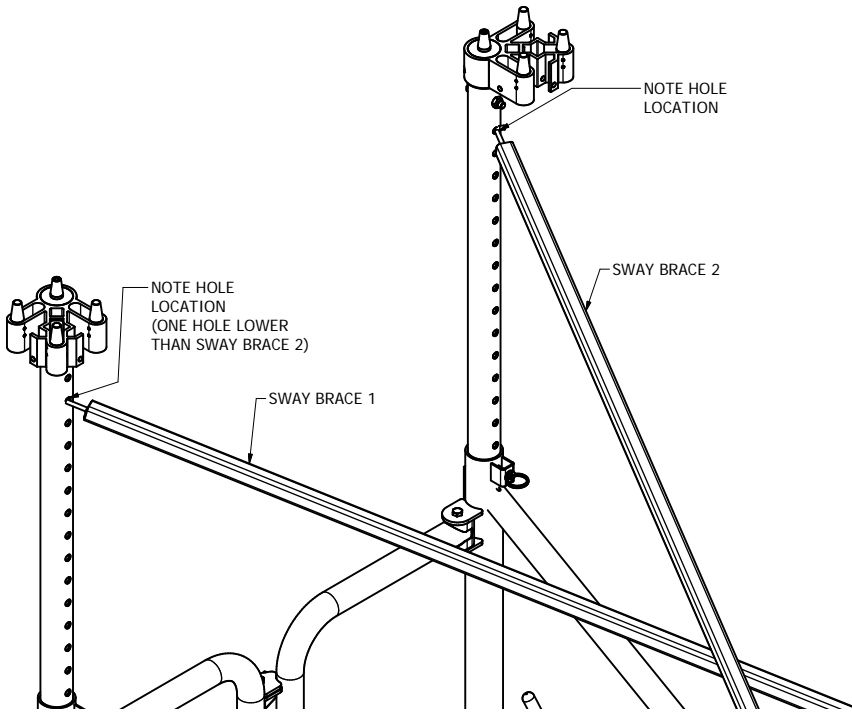

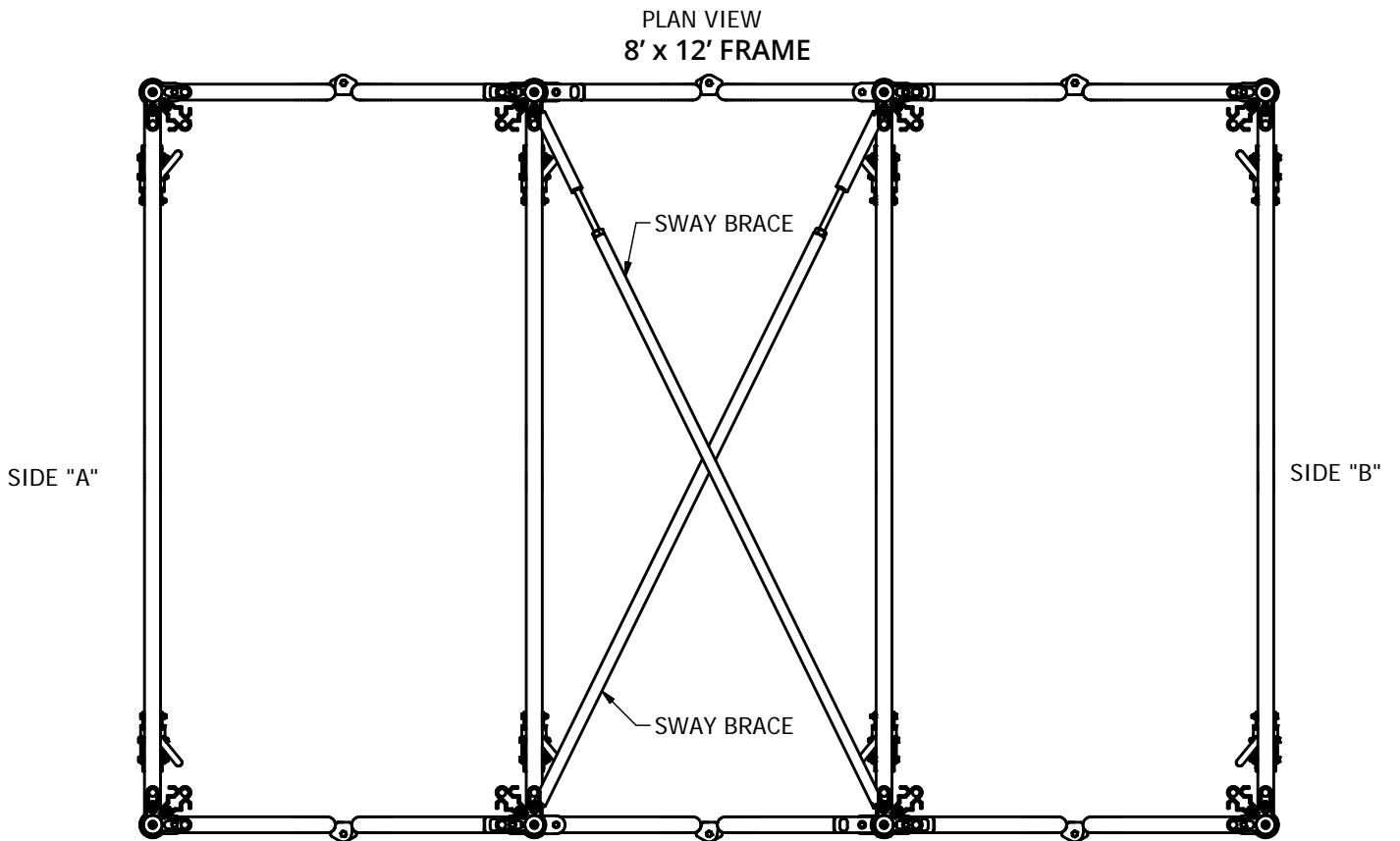
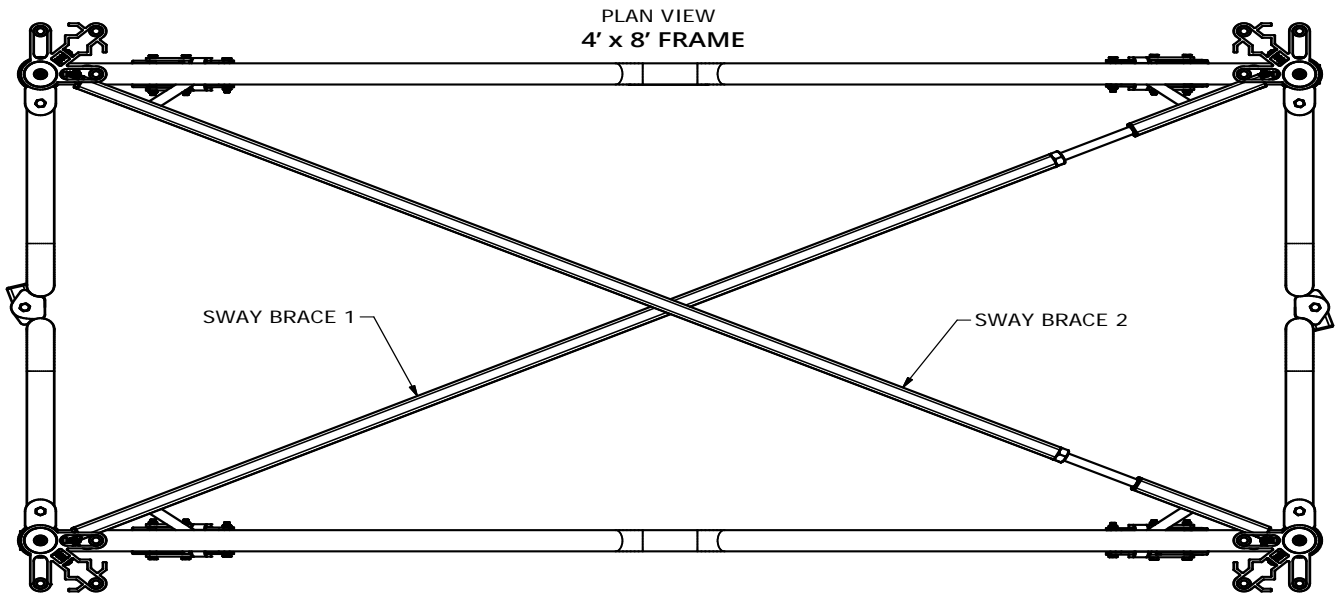

PLAN VIEW  
8' x 8' FRAME

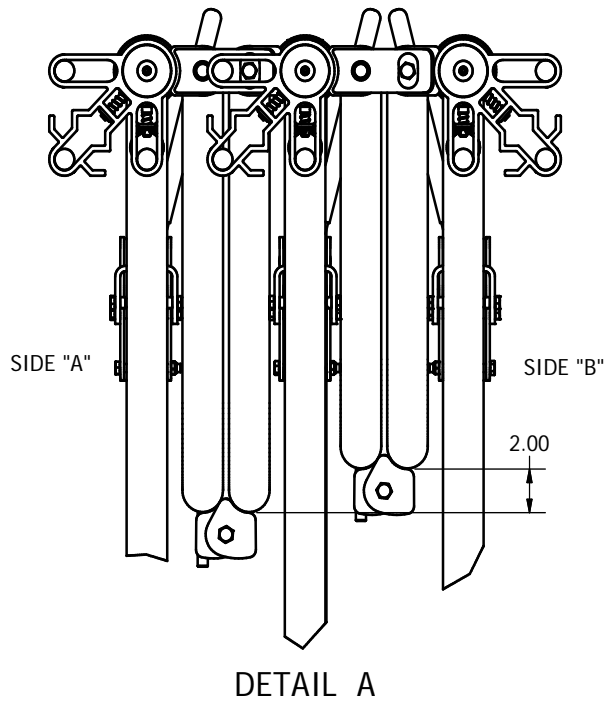
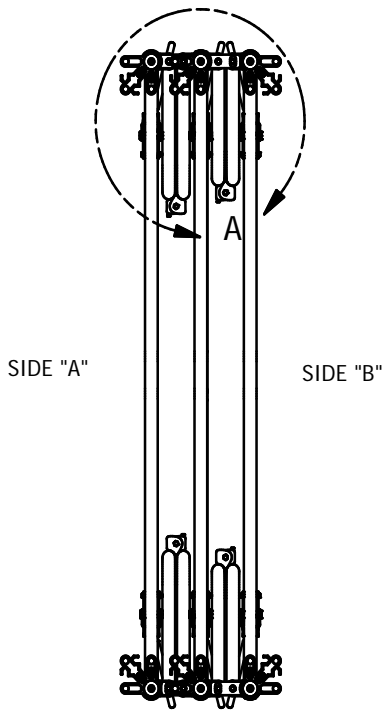
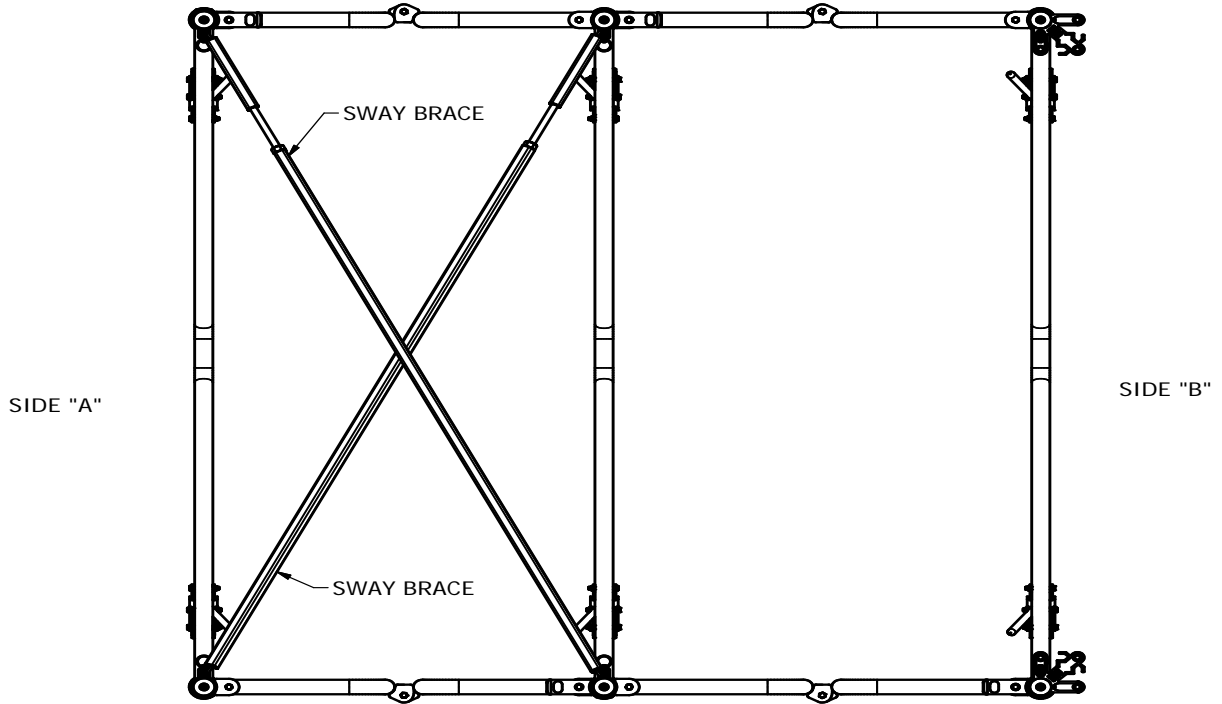

---

# Stacking Tray

1. Place first frame unit on glides/feet. Adjust glides/feet as required to ensure frame unit is level.
2. Adjust columns to lowest height. See page 3 for details.
3. Mount correct Stacking Tray. Note: The 8'x12' uses BLACK Stacking Trays. The 8'x8' uses SILVER Stacking Trays. The 4'x8' uses BLACK or SILVER Stacking Trays. The outer holes must always be used; see figures on page 18. Any pivot pins that will be under the stacking trays must be retracted to the storage position.
4. Adjust all glides/feet on unit to go on top to ensure frame is level. Lift 2<sup>nd</sup> unit on top of Stacking Tray. Make sure outermost glides/feet are all the way to the ends of the stacking trays.
5. Repeat steps 2 through 4 for 3<sup>rd</sup> level unit.
6. Do not stack more than 3 high.

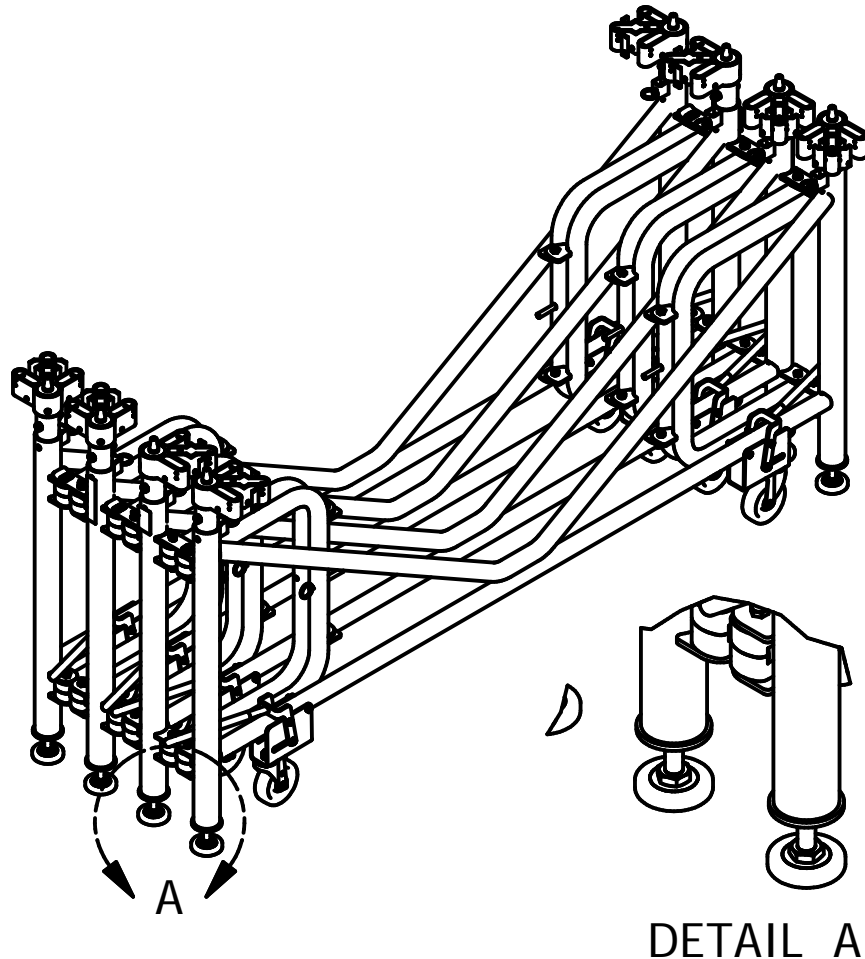



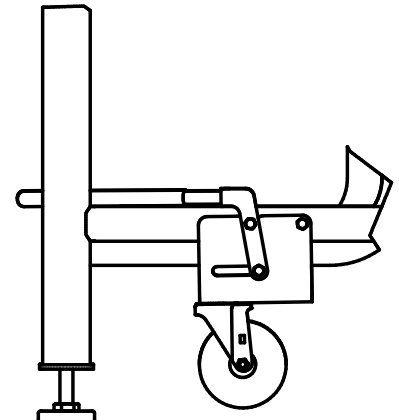
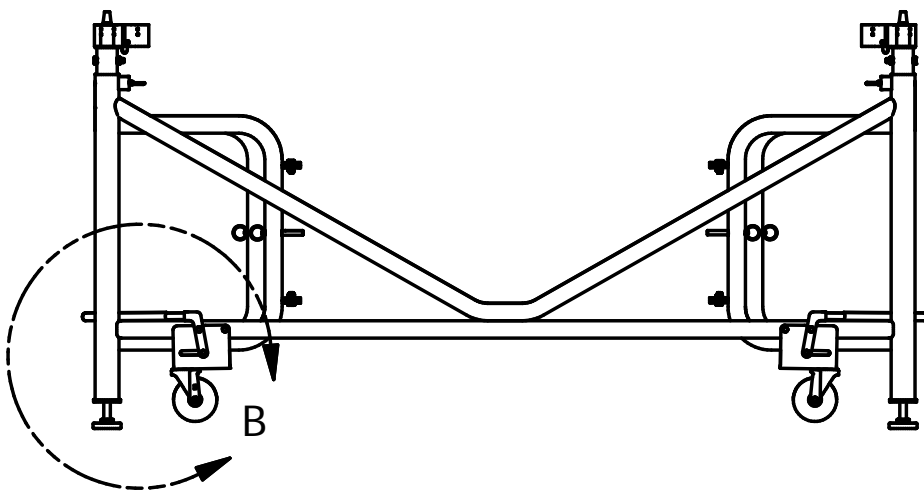

DETAIL B

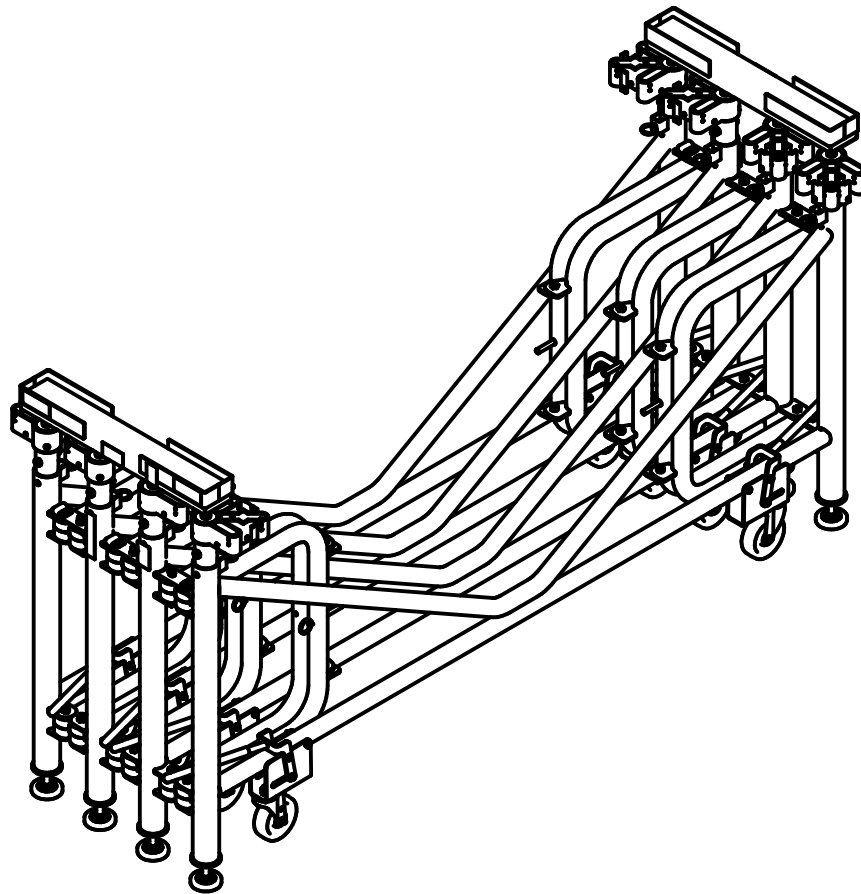

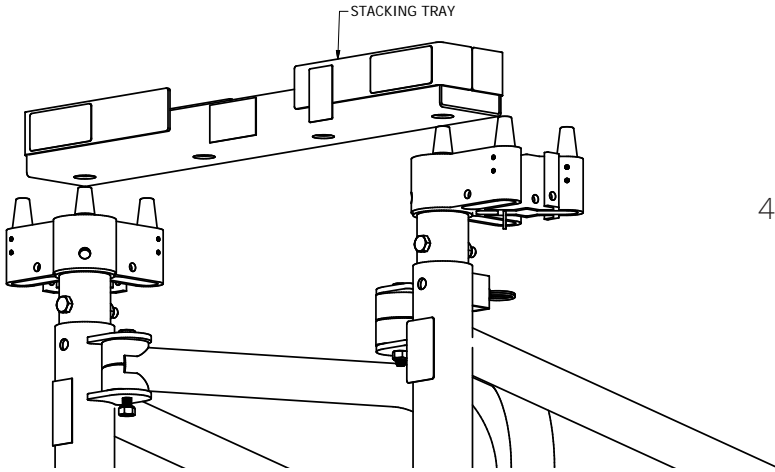

4' x 8' Frame

or

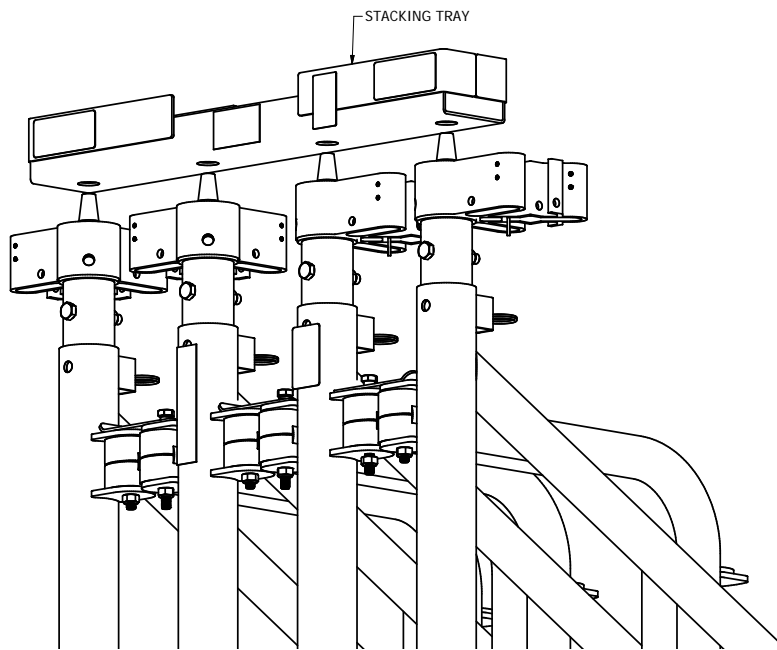

8' x 12' Frame

or

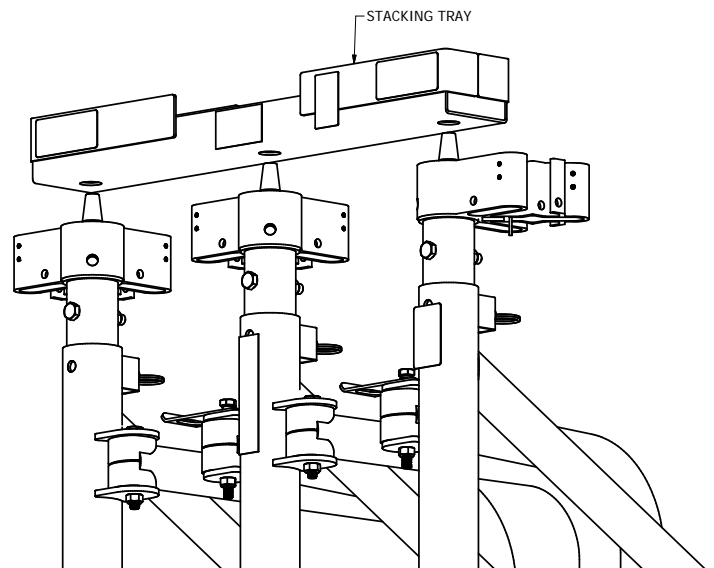

8' x 8' Frame

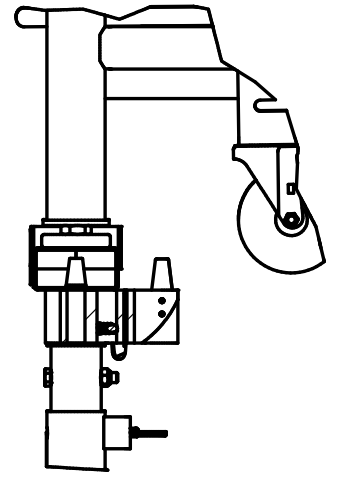
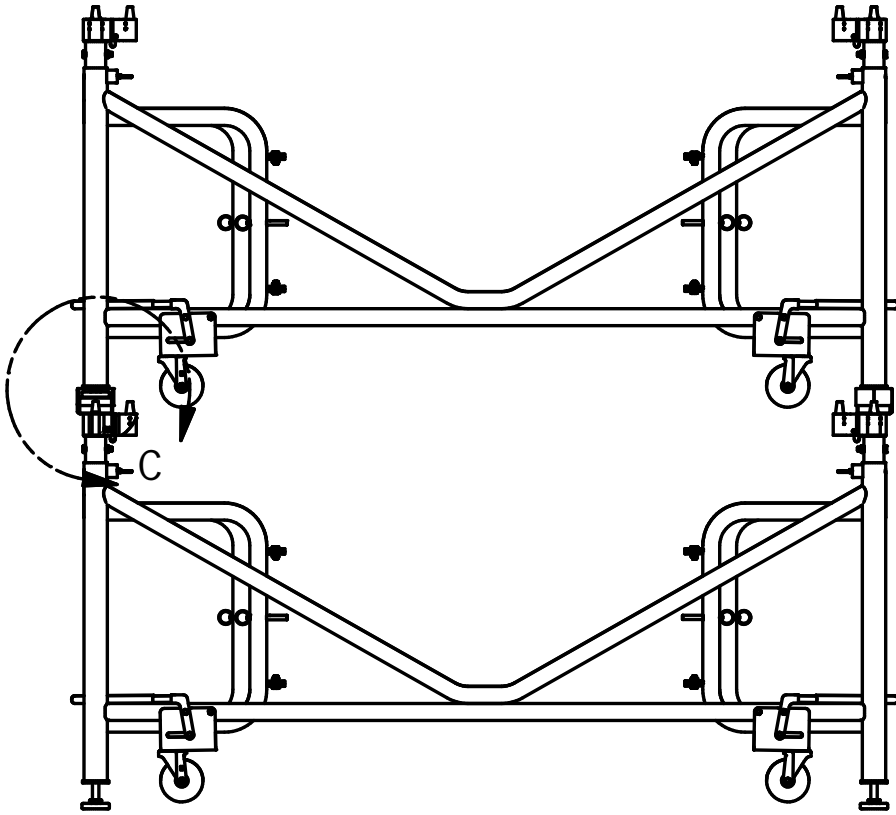

DETAIL C

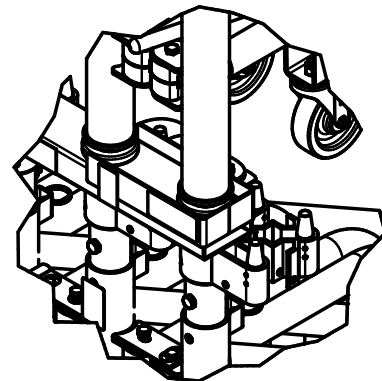
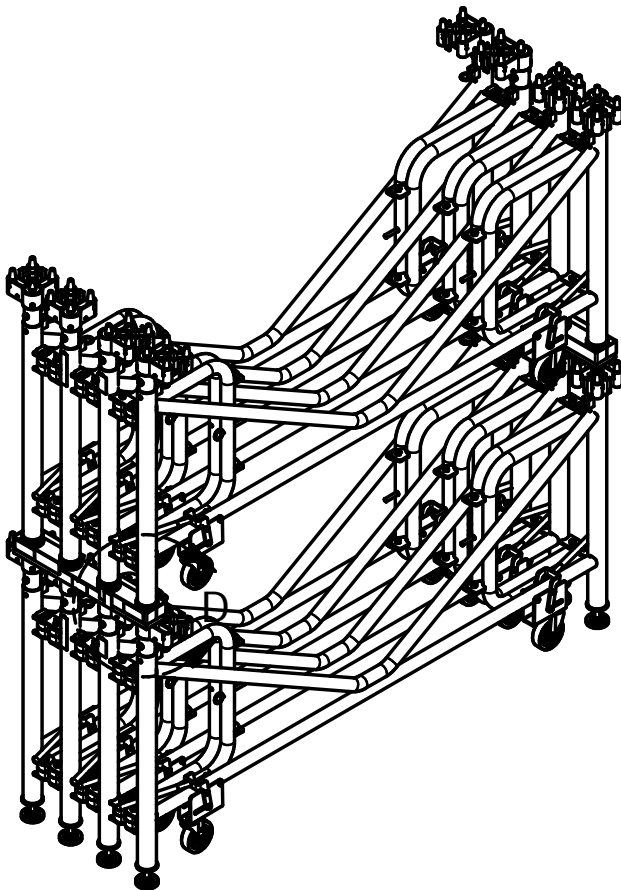

---

Please have the serial number of the product when contacting customer service to receive assistance for:

- Selecting replacement parts/decals
- Repairing the product
- Adjusting and operating the product
- Obtaining online assistance



800.424.0796 (phone)  
952.829.5141 (fax)  
[www.sicoinc.com](http://www.sicoinc.com)

SICO Incorporated  
7525 Cahill Road  
Minneapolis, MN 55439

---